

Aviera

User Manual

INSTALLATION AND RECONFIGURATION GUIDE



High traffic.
Low stress.



Aviera

The Aviera collection was developed specifically for high traffic areas. Complementary wood or metal frame/arm styles offer interior design flexibility. The stylish collection includes versatile guest, patient, bariatric and multi-seating, bringing new meaning to the term customizable. Seats can be specified in 21", 24", 30" and 44" widths and there are two back types. Linking tables round out the offering to create an ideal solution for high-traffic entry, reception, waiting and common areas.

Icon Descriptions

While reading through this User Guide you may see various icons. Here's what they mean:



This icon calls attention to information that may enhance your enjoyment or use of the product.



The information icon indicates that there is something that you should pay special attention to while using or working with the product.



This symbol indicates that there is a caution or warning about something that could damage your product.

Contents

Icon Descriptions	3
Multi-Seating Overview	4
What is Multi-Seating?	4
Replaceable Components	4
Design and Space Planning	5
Ordering	5
Features	5
Connecting Guest and Patient Chairs	6
Assembly & Installation	6
Linking to Tables	6
Ganging	6
Reconfiguration	7
Pre-Configured Multi-Seating	8
Assembly & Installation	8
Linking to Tables	8
Ganging	8
Reconfiguration	8
Freespan Multi-Seating	9
Assembly & Installation	9
Linking to Tables	9
Ganging	9
Reconfiguration	9
Start/Center/End Multi-Seating	10
Assembly & Installation	10
Tools Required	10
Included Hardware	10
Linking to Tables	13
Ganging	13
Reconfiguration	13
Creative Seating Solutions	15
Linking Tables	16
Assembly & Installation	16
Tools Required	16
Included Hardware	16
End Table	17
Center Table	18
Corner 45° Table	19
Corner Square 90° Table	20
Corner Round 90° Table	21
Replacing Components	22
FAQs	25
Appendix	26
Ordering	26
ANSI/BIFMA	26
Weight Capacity	26
CAL 133	27
Sustainability	27
Resources	27
Warranty	28

MULTI-SEATING OVERVIEW

What is Multi-Seating?

Multi-seating is a configuration of two or more seats. Seats may be linked together in any combination of widths and back types, with linking tables connecting chairs or placed at ends. Even stand-alone Guest and Patient chairs may be connected together via tables or optional ganging brackets.

Replaceable Components

Aviera is designed for easy field replacement and reconfiguration. All of the following components can be ordered separately. See the current Price Guide for parts pricing.

Backs

- 21" guest back
- 24" guest back
- 30" guest back
- 44" guest back
- 21" patient back
- 24" patient back
- 30" patient back

Seats

- 21" seat
- 24" seat
- 30" seat
- 44" seat

Arms

- Maple open arm
- Maple inner wood arm
- Maple arm with polyurethane arm cap
- Beech open arm
- Beech inner wood arm
- Beech arm with polyurethane arm cap
- Metal arm with polyurethane arm cap
- Metal arm with wood arm cap
- Solid surface arm cap
- Upholstered arm insert
- Polyurethane arm cap (for wood arm only)

Design and Space Planning

When planning multi-seating and linking tables in a variety of configurations, accuracy is critical. Dimensions have to be just right, and our understanding of what you want must exactly match your vision. When we receive your order for multi-seating and linking tables, our expert design team will spring into action to verify all the elements of your SitOnIt Seating arrangement. The Visual Confirmation you receive and approve assures that what ends up at your door is exactly what you wanted.

Ordering

Component pricing allows the specifier to add or subtract features and options from the base model, resulting in exactly the right chair for the need.

When ordering a multiple seating layout, begin at the left (facing the chair). A drawing showing the configuration of the multi-seating and tables is required with each purchase order sent to purchaseorder@exemplis.com. After an order is received a visual confirmation will be sent to the customer to verify every element. For orders in excess of 50 seat positions, please contact Customer Support for lead time.

Features

Aviera is a beautiful, durable, and versatile seating solution designed for high traffic areas where design flexibility, easy maintenance and limiting bacteria are important.

- Designed for high traffic areas
- Guest, patient, and multi-seating configurations
- Wood or metal arm and frame choices
- Clean-out space
- Steel frame construction with metal-to-metal connection
- Silver ion anti-microbial wood finishes
- Aluminum arm and frame will not rust or corrode
- Wall-saver design
- Occasional and cube tables complement linking tables
- Field replaceable parts
- Bariatric seat sizes
- Arm design provides support for easy ingress and egress
- Multi-seating configurations
- 4 wood stain finishes and three metal finishes
- Durable polyurethane arm cap (optional for wood arms)
- Optional upholstered arm inserts
- Easy maintenance with field-replaceable parts and arm caps
- 500 lb. weight capacity; bariatric model 750 lbs. weight capacity
- 12-Year Warranty
- All options and 1000's of textiles ship in 10 days

CONNECTING GUEST AND PATIENT CHAIRS

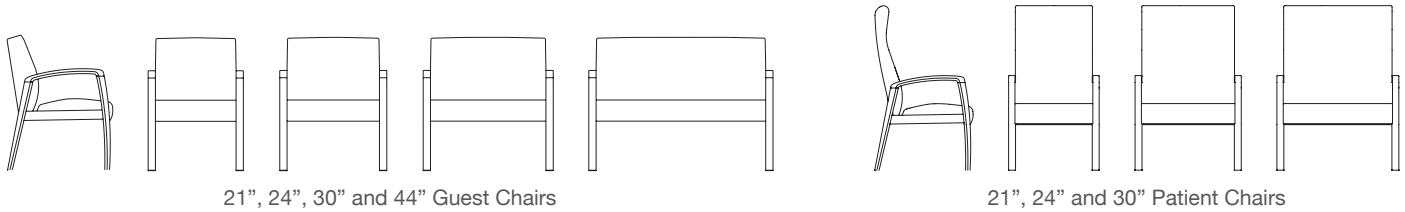

Stand-alone Guest and Patient chairs can be ganged together or connected via a Linking Table to become a multi-seating configuration.

Assembly & Installation

Guest and Patient chairs require no assembly.

Linking to Tables

Tables can be connected to either side of, or between, Guest and Patient chairs.

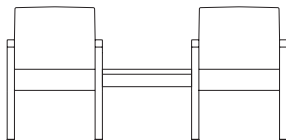

EXAMPLE 1

Example 1

Two Guest chairs with a Linking Table form a basic multi-seating configuration.



For step-by-step instructions on how to link Guest or Patient chairs to tables see the Linking Tables section.

Ganging

Chairs with different seat sizes and back types can be ganged using the optional ganging bracket.

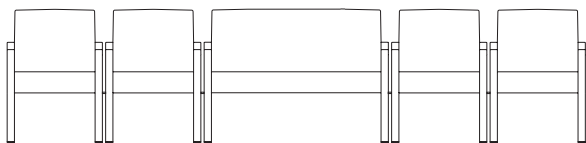

EXAMPLE 2

Example 2

Four 21" chairs are ganged with a 44" chair.



To reduce the number of legs this configuration can be duplicated using Aviera Multi-seating Start, Center (x3), and End elements.

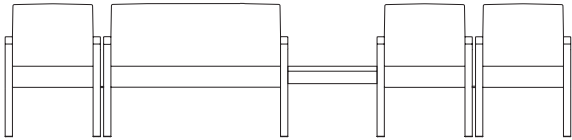

EXAMPLE 3

Example 3

Two sets of ganged Guest chairs incorporating different size seats linked with a table.



To reduce the number of legs this configuration can be duplicated using Start and End elements on the left and a 2-seat Pre-Configured or Freespan on the right.

Reconfiguration

Reconfiguring individual Guest or Patient chairs is simple. Since stand-alone chairs have both arms and all four legs no additional parts are required.

If chairs are ganged simply remove the ganging bracket and re-position the chairs. Reattach the ganging bracket if desired. If the chairs are connected to a Linking Table detach the table from the chair(s). Tables are reversible. An End Table on the left can be repositioned on the right. Or chairs flanking a Center Table can be oriented in opposite directions.

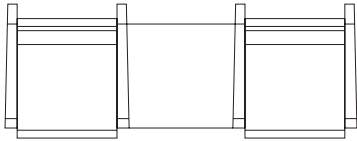

Both chairs face one direction

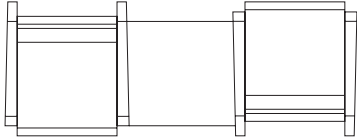

Chairs face in opposite directions

EXAMPLE 4

Example 4

In the example one chair has been reversed while the table and other chair remain unchanged.

PRE-CONFIGURED MULTI-SEATING

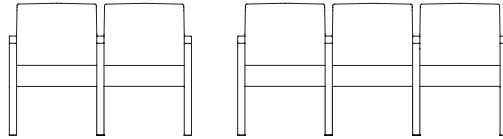

2-Seat and 3-Seat Pre-Configured Multi-Seating

Pre-Configured multi-seating is designed for seating configurations of two or three seats. All seats must be the same size and type; for example, two 24" seats.

Assembly & Installation

Pre-Configured multi-seating requires no assembly if the fully assembled shipping option is selected. If assembly is required see the instructions for Start/Center/End.

Linking to Tables



Tables can be connected to either side of a Pre-Configured element, but not in-between.

For step-by-step instructions on how to link Pre-Configured seating to tables see the Linking Tables section.

Ganging

Pre-Configured multi-seating can be ganged with standalone Patient and Guest Chairs, other Pre-Configured seating or with Freespan and Start/Center/End configurations using an optional ganging bracket.

Reconfiguration

Pre-Configured multi-seating cannot be reconfigured. If reconfiguration is anticipated, order Start/Center/End elements.

FREESPAN MULTI-SEATING

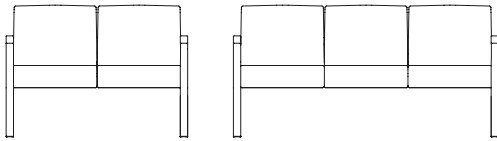

2-Seat and 3-Seat Freespan Armless

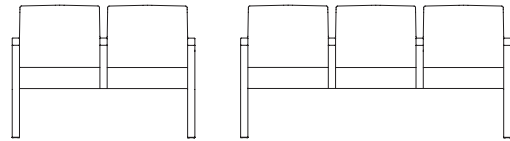

2-Seat and 3-Seat Freespan with Arms

Freespan multi-seating is designed to be used for configurations of two or three seats when a reduced number of legs is required.

Assembly & Installation

Freespan multi-seating requires no assembly.

Linking to Tables

Tables can be connected to either side of a Freespan element, but not in-between. For step-by-step instructions on how to link Freespan seating to tables see the Linking Tables section.

Ganging

Freespan multi-seating can be ganged with other Freespan elements or with Pre-Configured and Start/Center/End elements using an optional ganging bracket.

Reconfiguration

Freespan multi-seating cannot be reconfigured to create single-seat or two-seat solutions.

START/CENTER/ END MULTI-SEATING

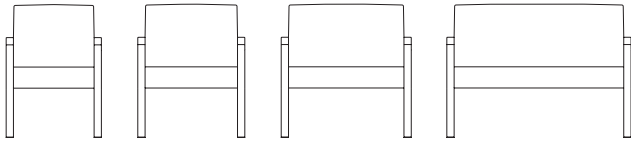

21", 24", 30" and 44" Start Elements

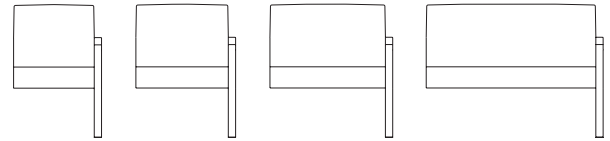

21", 24", 30" and 44" Center and End Elements

Start/Center/End is the most versatile multi-seating and is designed for configurations requiring more than three seats. Seat size and back type may be mixed. For example, three 21" seats (start/center/center) with guest backs and one 30" seat (end) with a patient back can be configured together.

Start/Center/End multi-seating is available in four seat widths and two back types. There is no limit to the number of Centers that can be placed between a Start and End. Seat widths, back types and arm styles may be mixed to create all sorts of seating.

Assembly & Installation

Start/Center/End multi-seating elements are shipped completely assembled in the box. To create a configuration the seats must be attached together. Build the configuration from left to right (facing the chair) beginning with the Start section. Then add as many Centers as necessary, finishing with an End. The instructions below show how to add Center and End elements.

Tools Required



(not included)
3/16" Allen wrench
(hex key)

Included Hardware

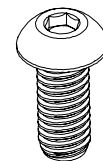

(applies to Center and
End elements only)
Six 5/16 x 3/4" bolt

Steps

1. Unpack the Start, End and all Center elements from shipping containers and locate hardware.



The hardware bag will either be stapled to the bottom of the chair or attached to one of the inserts in the box.

2. Begin with the Start element (fig. 1). This piece can be identified because it is the only element with four legs and two arms.

The following steps show how to attach the Center element (fig. 2). If more than one Center is specified or multiple seat widths or back types are involved refer to the space planning layout or the Visual Confirmation to verify seat size and back type.



Build the configuration from left to right (facing the chair) beginning with the Start section.

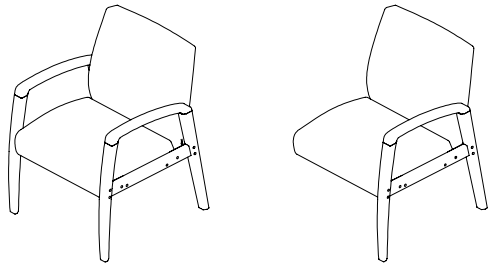

FIG. 1

FIG. 2

3. To connect the Start and Center elements, first remove the seat from the center element. To remove the seat, turn the chair over. Locate two tabs under the front of the seat (fig.3). Push the clips open and rotate the seat off of the steel rod in back. Align the seat support bar and the back of the Center element with the adjacent Start element.



The support bar runs front to back on the side at the bottom of the seat.

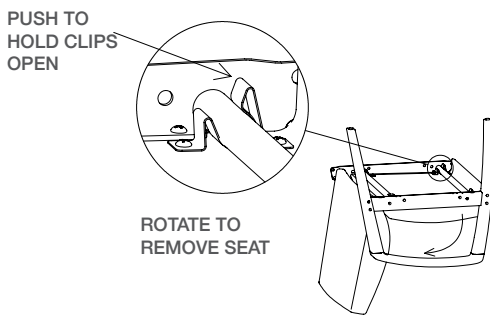
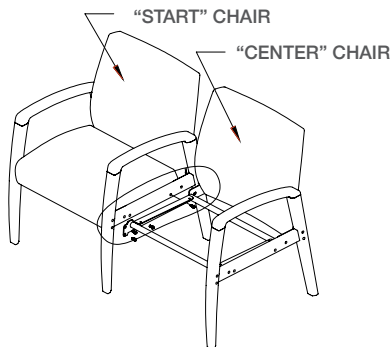
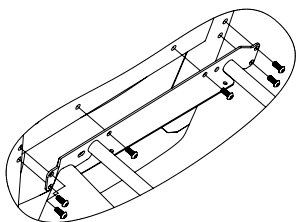
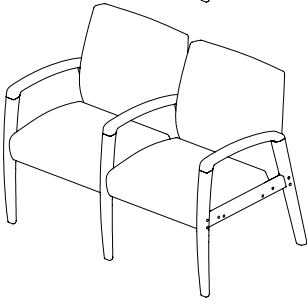
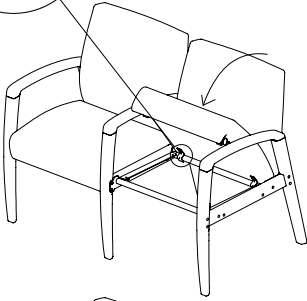
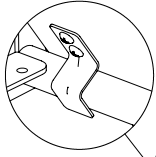

FIG. 3



4. With a 3/16" Allen wrench or hex key install six 5/16 x 3/4" thread hex bolts into the left side of the Start chair, using the holes indicated. Install all screws by hand before tightening. Fully tighten screws with all chair legs on the floor.





5. Reinstall the seat by hooking the back clips under the steel rod. Slip the seat back over the front tabs and push down. The Start and Center elements are now connected.

6. Repeat steps 3-5 for as many Center elements as necessary.

7. Finish the configuration by attaching the End element in the same manner as the Center element(s).

Linking to Tables

Tables can be connected to either side of a Start/Center/End configuration, but not in-between. **See the Linking Tables section for assembly and installation instructions.**

Ganging

Start/Center/End multi-seating can be ganged with other Start/Center/End elements or with Pre-Configured and Freespan elements using an optional ganging bracket.

Reconfiguration

Start/Center/End multi-seating can be reconfigured into any number of seating solutions, provided a Start and an End are used (a Center is not required).

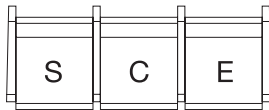

EXAMPLE 5

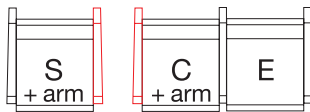

EXAMPLE 6

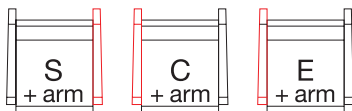

EXAMPLE 7

Example 5

A basic three-seat Start/Center/End configuration.

Example 6

The original seating reconfigured into a single chair and a 2-seater. It requires a new right arm for the original Center component (C) and a new left arm for the Start component (S) due to the through holes.



Additional arms can be ordered from the replacement parts section of the current Price Guide.

Example 7

The original multi-seating is reconfigured into three stand-alone chairs through the addition of two more arms – a right arm for the Center component and a right arm for the End component.



The configuration shown above can be more efficiently accomplished with stand-alone Guest or Patient chairs.

It is easy to add more center elements to create even longer seating arrangements.

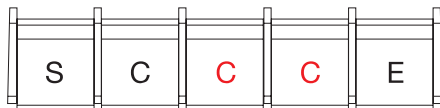

EXAMPLE 8

Example 8

The original configuration has been expanded by the addition of two Center components.

KEY
S – Start
C – Center
E – End

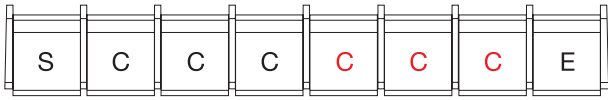

EXAMPLE 9

Example 9

Expanding the previous configuration by the addition of three more Center elements.

One of the easiest ways to reconfigure a multi-seating arrangement is with a Linking Table. Remember that tables can only be connected to a Start or End component, and that all configurations are built left to right.

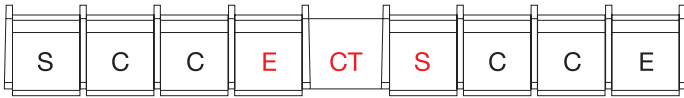

EXAMPLE 10

Example 10

Inserting a linking table into the previous configuration requires the addition of new End and Start elements.

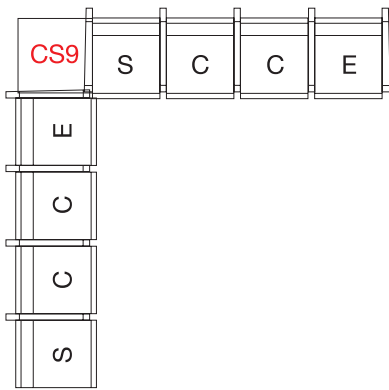

EXAMPLE 11

Aviera multi-seating components can be arranged in endless configurations – linear, square, circular and serpentine – and are easy to reconfigure if layout requirements change.

Example 11

The linear configuration in the previous example has been transformed into an “L” shape by replacing the Center table with a Square 90° table.

Example 12

A practical “U” configuration can be created by adding another Square 90° table and a new sequence of Start/Center/End multi-seating.

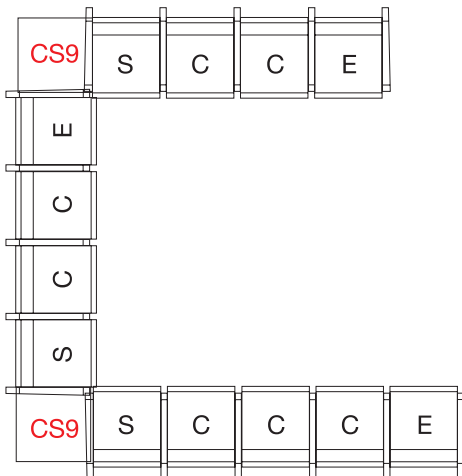

EXAMPLE 12

KEY
S – Start
C – Center
E – End
CT – Center Table
CS9 – Square 90° Table

CREATIVE SEATING SOLUTIONS

Creative configurations of tables and S/C/E units

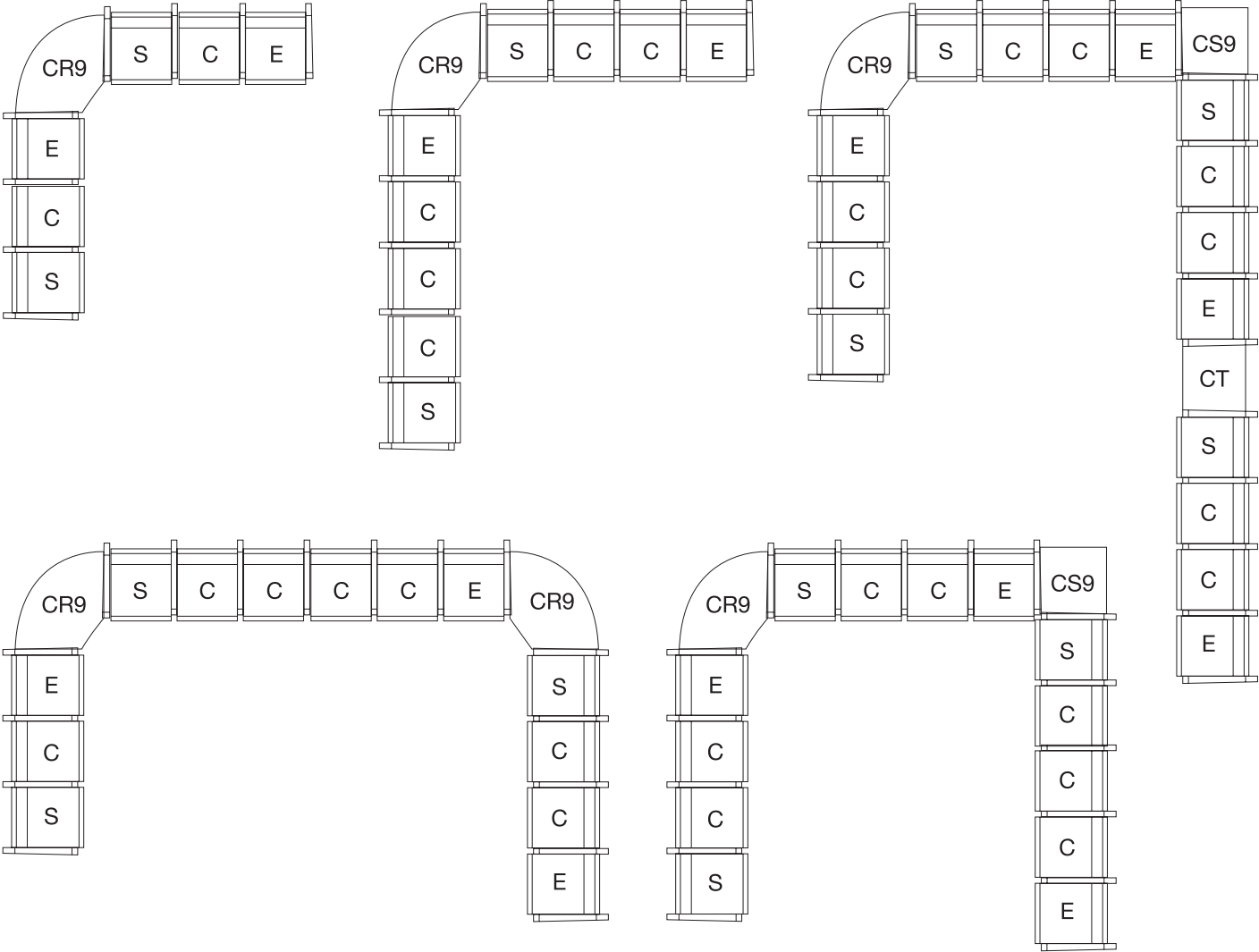

Mezzanine occasional or cube tables can be added to create even more configurations.

KEY
 S - Start
 C - Center
 E - End
 CT - Center Table
 CS9 - Square 90° Table
 CR9 - Round 90° Table

LINKING TABLES



End

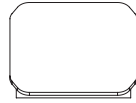

Center

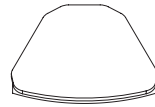

Corner 45°

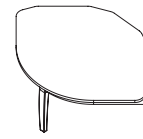

Round 90°

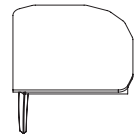

Square 90°

Tables are like bridges joining chairs and multi-seating elements. Connect like items together or mix it up. For instance, a table can link to a Guest or Patient chair on one side and a Pre-Configured, Freespan, Start or End element on the other. End tables have two legs, and 90° radius and square tables have one leg.



In a Start/Center/End configuration a table must connect to either a Start or an End.

Assembly & Installation

Start/Center/End multi-seating elements are shipped completely assembled in the box. To create a configuration the seats must be attached together. Build the configuration from left to right (facing the chair) beginning with the Start section. Then add as many Centers as necessary, finishing with an End. The instructions below show how to add Center and End elements.





Tools Required



(not included)
Phillips screwdriver

Included Hardware

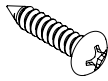
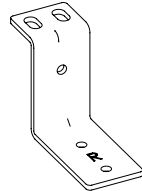
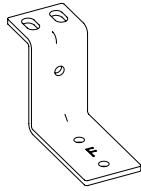
Hardware to attach tables to chairs is packaged inside the table carton along with installation instructions.

Table Type	 10-32 x 1-1/2" Phillips machine screw (for wood legs) or 10-32 x 3/4" Phillips machine screw (for metal legs)	 #12 x 5/8" Phillips wood screw	 #12 x 1" Phillips wood screw	 R bracket (for rear of chair)	 F bracket (for front of chair)	 Table Leg
End	4	4	4	1	1	2
Center	0	8	8	2	2	0
Corner 45°	0	8	8	2	2	0
Square 90°	2	8	8	2	2	1
Round 90°	2	8	8	2	2	1

End Table

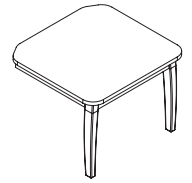

Steps

1. Unpack table and chair from shipping containers and locate parts.
(See chart at the top of this section for parts list and pictures.)



Always build configurations from left to right as you face it. End tables are reversible, meaning that they can be placed at either end of a configuration.

2. Turn the table top upside down.

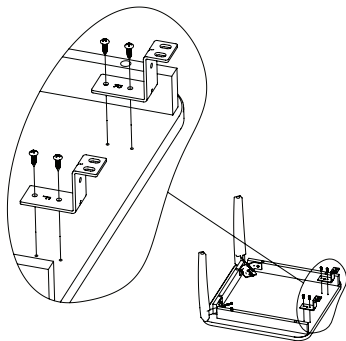

3. Place the R bracket at the rear of the table top and screw two #12 x 5/8" Phillips wood screws through the bracket into the underside of the table top. Repeat for the front F bracket.



Reverse the placement of the R and F brackets if the end table is to be installed to the right of the chair.

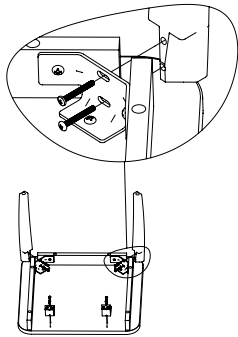

4. Screw two 10-32 x 1-1/2" Phillips machine screws (for wood legs) or two 10-32 x 3/4" Phillips machine screws (for metal legs) through the bracket at one corner of the table and into a table leg. Repeat for the second leg.

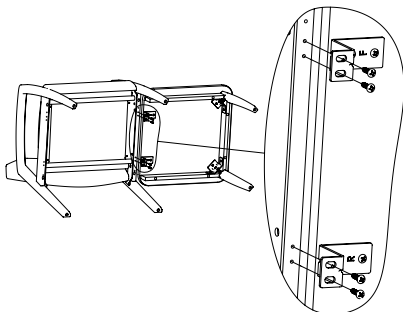

5. Orient the table with legs opposite the chair. Tilt the chair and table back to the floor. Use four #12 x 1" Phillips wood screws to screw the front and rear brackets into the seat support bar.



Install all screws to a loose fit, aligning the table with the chair to make it sit straight with the arms.

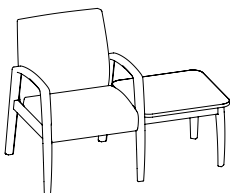

6. Tighten all screws and return the table and connected chairs to an upright position.

Center Table

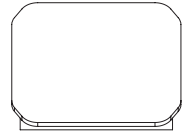

Steps

1. Unpack table and chairs from shipping containers and locate parts.
(See chart at the top of this section for parts list and pictures.)



Always build configurations from left to right as you face it. Center tables are reversible, meaning that a table may be placed between seats facing in opposite directions.

2. Turn the table top upside down.

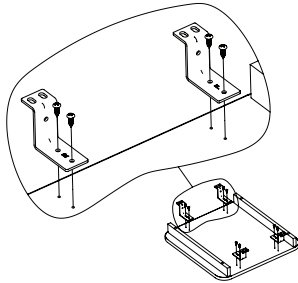

3. Beginning on the left side, place the R bracket at the rear of the table top and screw two #12 x 5/8" Phillips wood screws through the bracket into the underside of the table top. Repeat for the front F bracket.



Reverse the placement of the R and F brackets if the center table is to be installed between chairs facing opposite directions.

4. On the right side, place the R bracket at the rear of the table top and screw two #12 x 5/8" Phillips wood screws through the bracket into the underside of the table top. Repeat for the front F bracket.

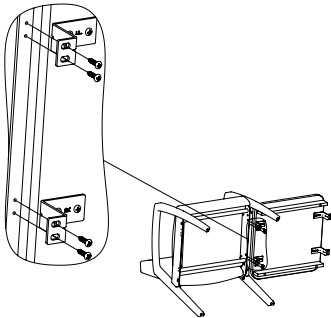

5. Tilt the left chair back to the floor and align the table top. Use four #12 x 1" Phillips wood screws to screw the front and rear brackets into the seat support bar.

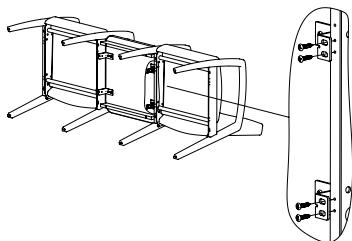

6. Tilt the right chair back to the floor and align the table top. Use four #12 x 1" Phillips wood screws to screw the front and rear brackets into the seat support bar.

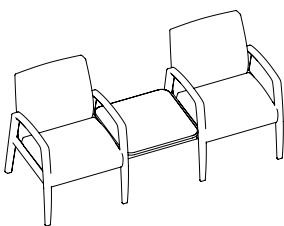

7. Tighten all screws and return the chairs and connected table to an upright position.

Corner 45° Table

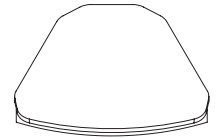

Steps

1. Unpack table and chairs from shipping containers and locate parts. (See chart at the top of this section for parts list and pictures.)



Always build configurations from left to right as you face it. Corner 45° tables are reversible, meaning that a table may be placed between seats facing in opposite directions.

2. Turn the table top upside down.

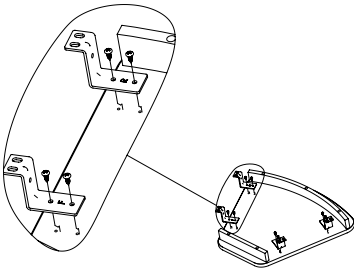

3. Beginning on the left side, place the R bracket at the rear of the table top and screw two #12 x 5/8" Phillips wood screws through the bracket into the underside of the table top. Repeat for the front F bracket.

4. On the right side, place the R bracket at the rear of the table top and screw two #12 x 5/8" Phillips wood screws through the bracket into the underside of the table top. Repeat for the front F bracket.

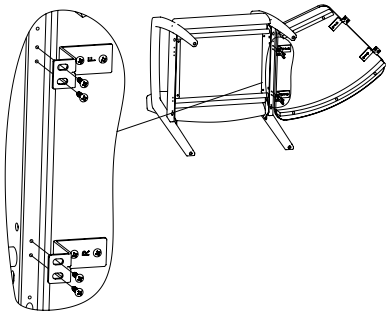

5. Tilt the left chair back to the floor and align the table top. Use four #12 x 1" Phillips wood screws to screw the front and rear brackets into the seat support bar.

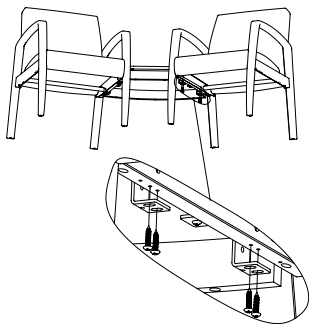

6. Return the connected chair and table to an upright position. Align the right chair with the table. Use four #12 x 1" Phillips wood screws to screw the front and rear brackets into the seat support bar.

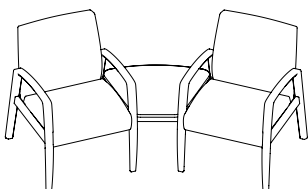

7. Tighten all screws to complete the assembly.

Corner Square 90° Table

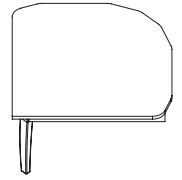

Steps

1. Unpack table and chairs from shipping containers and locate parts.
(See chart at the top of this section for parts list and pictures.)



Always build configurations from left to right as you face it. Corner 90° tables are reversible, meaning that a table may be placed between seats facing in opposite directions.

2. Turn the table top upside down.

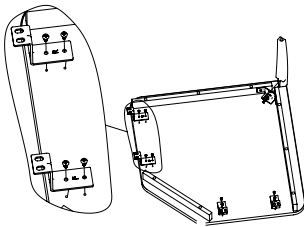

3. Beginning on the left side, place the R bracket at the rear of the table top and screw two #12 x 5/8" Phillips wood screws through the bracket into the underside of the table top. Repeat for the front F bracket.

4. On the right side, place the R bracket at the rear of the table top and screw two #12 x 5/8" Phillips wood screws through the bracket into the underside of the table top. Repeat for the front F bracket.

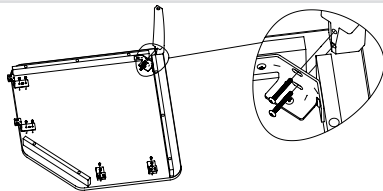

5. Screw two 10-32 x 1-1/2" Phillips machine screws (for wood legs) or two 10-32 x 3/4" Phillips machine screws (for metal legs) through the bracket at one corner of the table and into a table leg. Repeat for the second leg.

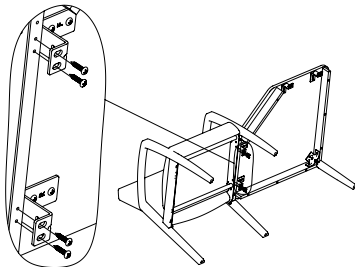

6. Tilt the left chair back to the floor, Orient the table with legs in back, on the floor. Use four #12 x 1" Phillips wood screws to screw the front and rear brackets into the seat support bar.



Install all screws to a loose fit, aligning the table with the chair to make it sit straight with the arms.

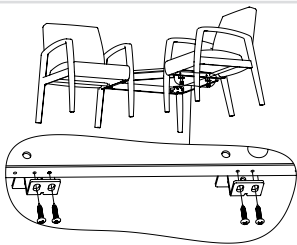

7. Return the connected chair and table to an upright position. Align the right chair with the table. Use four #12 x 1" Phillips wood screws to screw the front and rear brackets into the seat support bar.

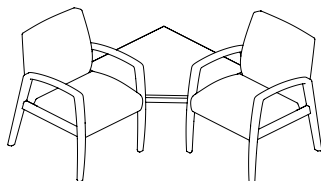

8. Tighten all screws to complete the assembly.

Corner Round 90° Table

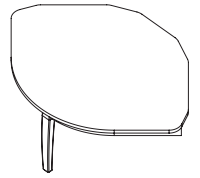

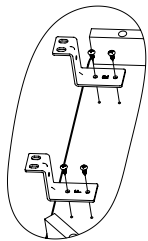
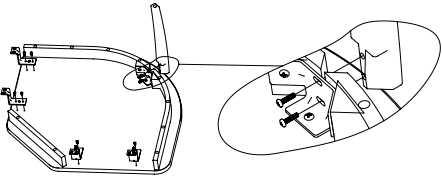
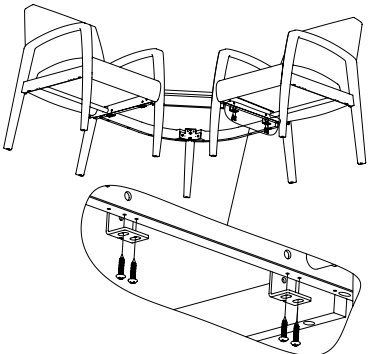
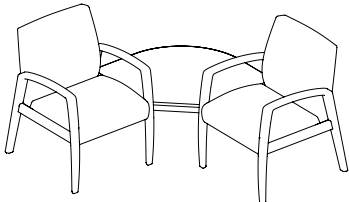
	Steps
	<p>1. Unpack table and chairs from shipping containers and locate parts. (See chart at the top of this section for parts list and pictures.)</p> <p>i Always build configurations from left to right as you face it. Corner 90° tables are reversible, meaning that a table may be placed between seats facing in opposite directions.</p>
	<p>2. Turn the table top upside down.</p> <p>3. Beginning on the left side, place the R bracket at the rear of the table top and screw two #12 x 5/8" Phillips wood screws through the bracket into the underside of the table top. Repeat for the front F bracket.</p>
	<p>4. On the right side, place the R bracket at the rear of the table top and screw two #12 x 5/8" Phillips wood screws through the bracket into the underside of the table top. Repeat for the front F bracket.</p> <p>5. Screw two 10-32 x 1-1/2" Phillips machine screws (for wood legs) or two 10-32 x 3/4" Phillips machine screws (for metal legs) through the bracket at one corner of the table and into a table leg [New Round Corner Table Figure B] Repeat for the second leg.</p>
	<p>6. Tilt the left chair back to the floor, Orient the table with legs in back, on the floor. Use four #12 x 1" Phillips wood screws to screw the front and rear brackets into the seat support bar.</p> <p>Tip Install all screws to a loose fit, aligning the table with the chair to make it sit straight with the arms.</p>
	<p>7. Return the connected chair and table to an upright position. Align the right chair with the table. Use four #12 x 1" Phillips wood screws to screw the front and rear brackets into the seat support bar.</p>

REPLACING COMPONENTS

Many Aviera components are field replaceable. Follow the steps below to replace a back, seat or arm.

Back Replacement

Guest/Patient/Pre-Configured/Multi-Seating Chairs

1. Unzip and remove the back upholstery.
2. Remove six 5/16" bolts in the bottom rear section of the back using a 3/16" Allen key.
3. Pull off the back and replace with the new back.
4. Re-install bolts.
5. Re-attach back upholstery and close the zipper.

Freespan Chairs

1. Unzip and remove the back upholstery.
2. Remove upholstery flaps from the rear of the chair (Velcro attached to frame).
3. Remove four Phillips wood screws from the frame.
4. Slide back out of the back bracket.
5. Re-install the new back by slipping it into the slot in the frame and pushing down.
6. Align pilot holes in back wood with those in the back bracket of the frame.
7. Re-install Phillips wood screws.
8. Wrap upholstery flaps with Velcro through to the rear of the chair and attach to frame back brackets.
9. Re-attach back upholstery and close the zipper.

Arm Replacement

Guest/Patient/Pre-Configured/Multi-Seating Chairs

1. Turn the chair upside down. Remove the seat by removing the four Phillips wood screws that secure the seat to the frame.
2. Remove the six 5/16" bolts that connect the frame to the arm using a 3/16" Allen key.
3. Remove the arm.
4. Replace the arm and loosely re-install the bolts.
5. Rest chair on the ground on all four legs. Ensure chair is level and tighten down bolts.
6. Turn the chair upside down and re-install seat with the wood screws.

Freespan Chairs

1. Unzip and remove the back upholstery.
2. Remove upholstery flaps from rear of chair (Velcro attached to frame).
3. Remove four Phillips wood screws from the frame.
4. Slide the back out of the back bracket.
5. Remove the seat using spring clips located under the front of the chair.
6. Remove the 5/16" bolt located inside the back bracket using a 3/16" Allen key. An extension tool maybe needed in order to reach the bolt. Do not lose the plastic washers.
7. Remove six- 5/16" bolts from the side of frame.
8. Remove the arm.
9. Replace the arm and loosely install all seven bolts. Ensure washers on upper most bolt are in the correct position (2 between arm and bracket, 1 between bracket and bolt).
10. Level chair on the ground and tighten all bolts.
11. Re-install back by slipping it into the slot in the frame and pushing down.12. Align pilot holes in back wood with those in the back bracket of the frame.
13. Re-install four Phillips wood screws.
14. Wrap flaps with Velcro through to the rear of the chair and attach to frame where Velcro is located.
15. Re-attach back upholstery and close the zipper.
16. Re-install the seat.

Arm Cap Replacement – without Arm Insert

1. Remove plastic caps on underside of arm top with flat head screwdriver or razor blade.
2. Remove three 10-32 nuts using a 3/8" socket.
3. Remove three 10-32 threaded studs using a 3/32" Allen key.
4. Remove arm cap and replace.
5. Install three 10-32 threaded studs using a 3/32" Allen key.
6. Install three 10-32 washer and nut using 3/8" socket. Hand-tighten only (too tight will leave depressions in top side of pad).
7. Re-install plastic caps over the holes.

Arm Cap Replacement – with Arm Insert (wood arms only)

1. Turn chair upside down.
2. Remove two #8 x 3”L wood screws on underside of stringer (#2 square drive for wood arms).
3. Push upholstered arm insert out of the chair from the bottom edge and remove.
4. Remove plastic caps on the underside of the arm top with a flathead screwdriver or razor blade.
5. Remove three 10-32 nuts using a 3/8” socket.
6. Remove three 10-32 threaded studs using a 3/32” Allen key.
7. Remove arm cap and replace.
8. Install three 10-32 threaded studs using a 3/32” Allen key.
9. Install three 10-32 washer and nut using a 3/8” socket. Hand-tighten only (too tight will leave depressions in top side of pad).
10. Reinstall plastic caps over holes.
11. Reinstall upholstered arm insert by aligning tabs in the top side of the arm with cutouts in the upholstery.
12. Push bottom portion of upholstery into the arm, align with center of arm stringer.
13. Reinstall two #8 x 3”L wood screws using a #2 square drive.

Seat Replacement

Guest/Patient Chairs

1. To remove the seat, turn the chair over.
2. Remove four #12 Phillips wood screws that hold the seat to the frame from below the chair that are easily accessible.
3. Replace the seat and re-install the four Phillips wood screws.

Freespan, Pre-Configured or Multiseating Chairs

1. To remove the seat, turn the chair over.
2. Locate two clips under the front of the seat.
3. Push the clips open and rotate the seat off of the steel rod in back.
4. Reinstall the seat by hooking the back clips under the steel rod. Slip the seat back over the front tabs and push down.

FAQs

Q: How can I change a configuration once it has been installed?

A: Start/Center/End configurations can be easily reconfigured with the addition of arms or additional Start/Center/End elements.

Q: Can I add a table to the middle of a Start/Center/End configuration?

A: Only the Start and End have finished arms, so a table cannot be placed in the middle. Instead, connect a Guest or Patient chair or Pre-Configured or Freespan seating to both sides of a table.

Q: How much assembly is required?

A: Pre-Configured and Freespan multi-seating ship completely assembled from the factory. Start/Center/End multi-seating requires some assembly.

Q: Can I mix guest and patient backs or different size seats?

A: Back types and seat sizes may be combined in Start/Center/End configurations but not in Pre-Configured multi-seating.

Q: Do I need a new table if I change my configuration?

A: Linking Tables can be reversed, so that an end table on the left may be repositioned on the right; or a table may be placed between seats facing in opposite directions.

Q: Can I buy additional Centers or Start/End components?

A: Yes! And our accurate fabric matching ensures that patterns will line up perfectly, even years after the initial order.

Q: How can I be sure that my order is correct?

A: After an order is received for multi-seating or seating with linking tables, a Visual Confirmation will be sent that verifies every element.

APPENDIX

Ordering

New Configurations

When ordering a multiple seating layout, begin at the left (facing the chair). A drawing showing the configuration of the multi-seating and tables is required with each purchase order sent to purchaseorder@exemplis.com. After an order is received a visual confirmation will be sent to the customer to verify every element. For orders in excess of 50 seat positions, please contact Customer Support for lead time.

Replacement Parts

Replacement parts can quickly be obtained by sending a purchase order to purchaseorder@exemplis.com. See the Price Guide for details.

ANSI/BIFMA

SitOnIt Seating is a member of the Business and Institutional Furniture Manufacturer's Association (BIFMA). Tests developed by BIFMA and approved by the American National Standards Institute (ANSI) determine the strength and durability of seating. Although testing is not a warranty or guarantee, our products meet or exceed BIFMA and ANS standards.

Weight Capacity

We design chairs and stools with rigid standards that test for arm and leg strength, load and impact. SitOnIt Seating Guest and Patient chairs have a 500 lb. weight capacity and bariatric models have a 750 lb. weight capacity.

Guest, Patient and Start/Center/End		Pre-Configured (arm and armless)		Freespan (arm and armless)	
21" Seat	500 lbs.	2-Seat (per seat)	500 lbs.	2-Seat (per unit)	525 lbs.
24" Seat	500 lbs.	3-Seat (per seat)	500 lbs.	3-Seat (per unit)	750 lbs.
30" Seat	750 lbs.				
44" Seat*	750 lbs.				

*Not available for Patient chair

CAL 133

Fire safety is a top priority at medical and educational facilities. SitOnIt Seating strongly supports CAL 133 standards and makes it easy for designers and buyers to specify CAL 133 chairs:

- Available in plastic, fabric and leather
- No delay – turnaround in 10 days or less
- CAL 133 models are available for every product collection
- COM fabric approval service
- Low incremental cost to specify CAL 133 compared to our competitors

Sustainability

Our commitment to sustainability makes it easier to design and build green, or upgrade your facility to the latest environmental standards.



Leed Certification

Earn points toward LEED certification thanks to our US manufacturing location and our consciousness of recycled material.



Environmental Data Sheets

Our Environmental Data Sheets are detailed documents declaring the percentage of recycling content, manufacturing process and indoor air emissions.



Greenguard Certification

All products have been tested and certified by the GREENGUARD Environmental Institute and have met the rigorous criteria required by GREENGUARD Children & Schools in accordance with the Collaborative for High Performance Schools.

Resources

[Aviera website](#)

[Aviera wood](#)

[Aviera metal](#)

[Aviera price guide](#)

[Aviera price worksheet](#)

[Aviera installation video](#)

[Aviera installation instructions](#)

[Aviera Visual Confirmation program](#)

[Mezzanine collection tables](#)

WARRANTY

SitOnIt Seating warrants to the original purchaser that our products will be free from defects in material and workmanship. Visit our website for the complete [SitOnIt Seating warranty](#).

Seating

12-Year Warranty – the entire time owned by the original purchaser for all chair components including glides, casters, frames and other structural elements.

Fabric & foam

5-Year Warranty – on all collections COM/COL not warranted for wear or long-term adhesion. Normal wear and tear is the responsibility of the customer.

Tables

12-Year Warranty – the entire time owned by the original end user.

Warranty Period

Warranted products are covered for all chair components, including frames and other structural elements, for the specified term owned by the original purchaser.

Repair or Replacement

We will repair or replace with a comparable product, at our option and without charge to the original purchaser, products or parts found to be defective during normal use (8 hours a day, 5 days per week).

Textiles and Leather

Since textiles vary in weave, thickness and memory, some creasing and/or gathering may occur during the upholstery application process. Due to natural variations over which we have no control, all products are sold subject to minor irregularities of color, surface, grain, and texture. Because leather is a natural product, variations of texture are common and should be expected. Leather will contain natural markings such as neck wrinkles, scratches, backbone marks and stretch marks. These distinctions give leather its unique characteristics and are considered to be part of the natural beauty of leather. We cannot warrant customer's own material (COM) or customer's own leather (COL).



6415 Katella Avenue, Cypress, California 90630

For the name and number of your local representative call, email or visit the website.

Aviera
High traffic. Low stress.

SitOnIt Seating
(877) 994-3366
sitonit.net
sales@sitonit.net



The images used within this website or document represent the logical use of the product(s) offered. The textiles, frame colors, accessories and options depicted are subject to change without notice. Refer to the current price list or contact Customer Support for the most up-to-date product information and specifications.

SitOnIt Seating, Aviera and Mezzanine are trademarks or registered trademarks of Exemplis Corporation. All other trademarks are property of their respective owners.

Printed in the USA.

© 2014 Exemplis Corporation.

SitOnIt • Seating®